

SI440 - SI1100 All Spark Guard Fitment .

Clip In Spark Guard

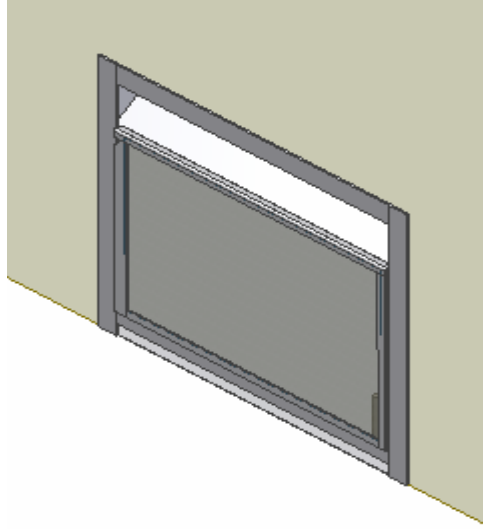

Firebox	SI 440	SI 600	SI 700	SI 700T	SI 780	SI 780T	SI 900	SI 1100	SI 1250	SI 1500
Clip In Spark Guard Width	386	546	646	646	727	727	847	1047	1195	1445
Clip In Spark Guard Height	395	395	395	445	395	475	525	575	725	725

Curved Spark Guard (Stand Alone)

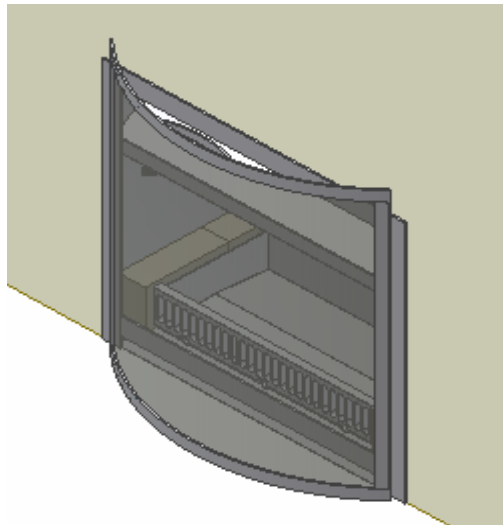

* Note : Curved Spark Guard not Available with SI440 & SI600 Fires .

Firebox	SI 700	SI 700T	SI 780	SI 780T	SI 900	SI 1100	SI 1250	SI 1500
Curved Spark Guard Width	700	700	765	765	900	1100	1250	1500
Curved Spark Guard Height	700	750	700	780	750	800	960	960

Due to continued product improvement, Warmington Ind LTD reserves the right to change product specifications without prior notification.

SI440 - SI1100 Clip In Spark Guard Fitment .

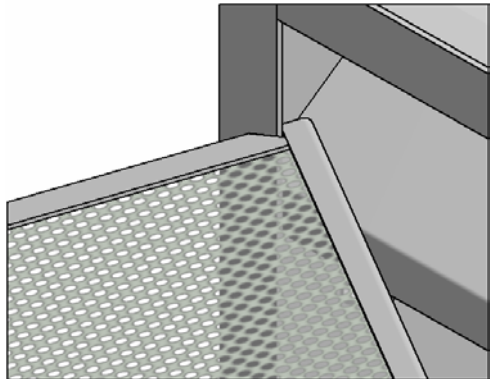

Holding the Spark Guard Horizontally to the face of the Fire , Insert Top Lefthand Side Knotch into the Upper Venting area as Shown in Diagram 1 : 4 .

*** Diagram 1:4 .**

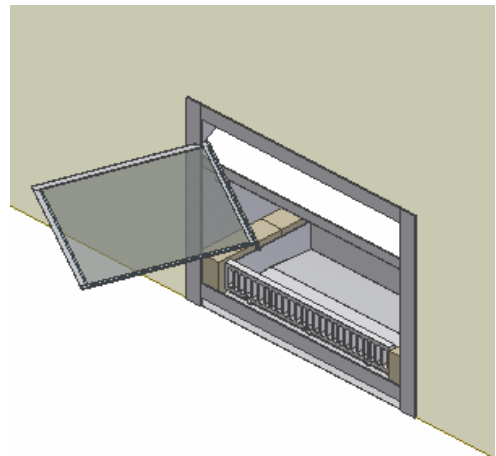

Swing Right Hand Side of Spark Guard into Position as Shown in Diagram 2:4 .

*** Diagram 2:4 .**

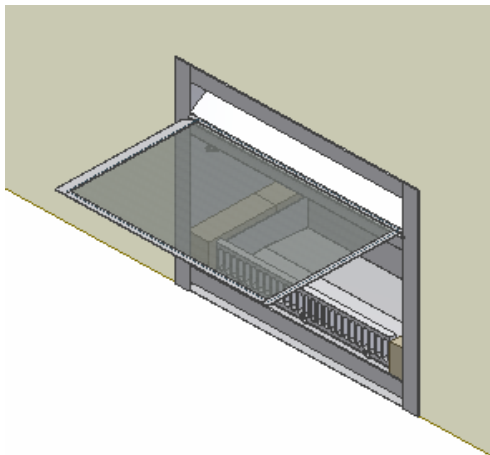

Once Righthand side is swung in Position , slide Spark Guard across to the Right until evenly sitting between Flanges as shown in Diagram 3:4 .

*** Diagram 3:4 .**

*** Diagram 3:4 .**

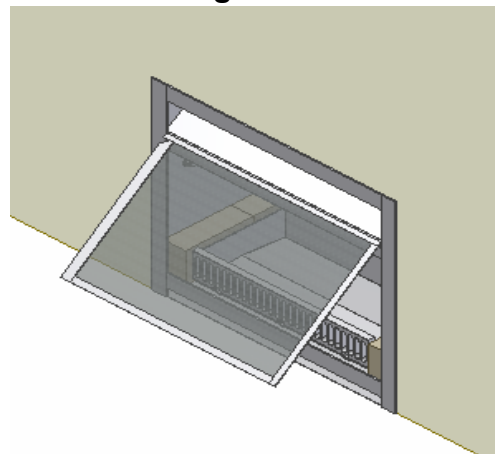

Lower Spark Guard into Position as Shown in Diagram 2:2 .