

SI 440-600-700-700T-780-780T-900-1100

RETRO—Fitted Open Fire Wood Burner

Installation Instructions into Existing Brick / Pre Cast Chimney .

***Option 1 : Use Existing Chimney**

***Option 2 : Use Adaptor & Fluekit**

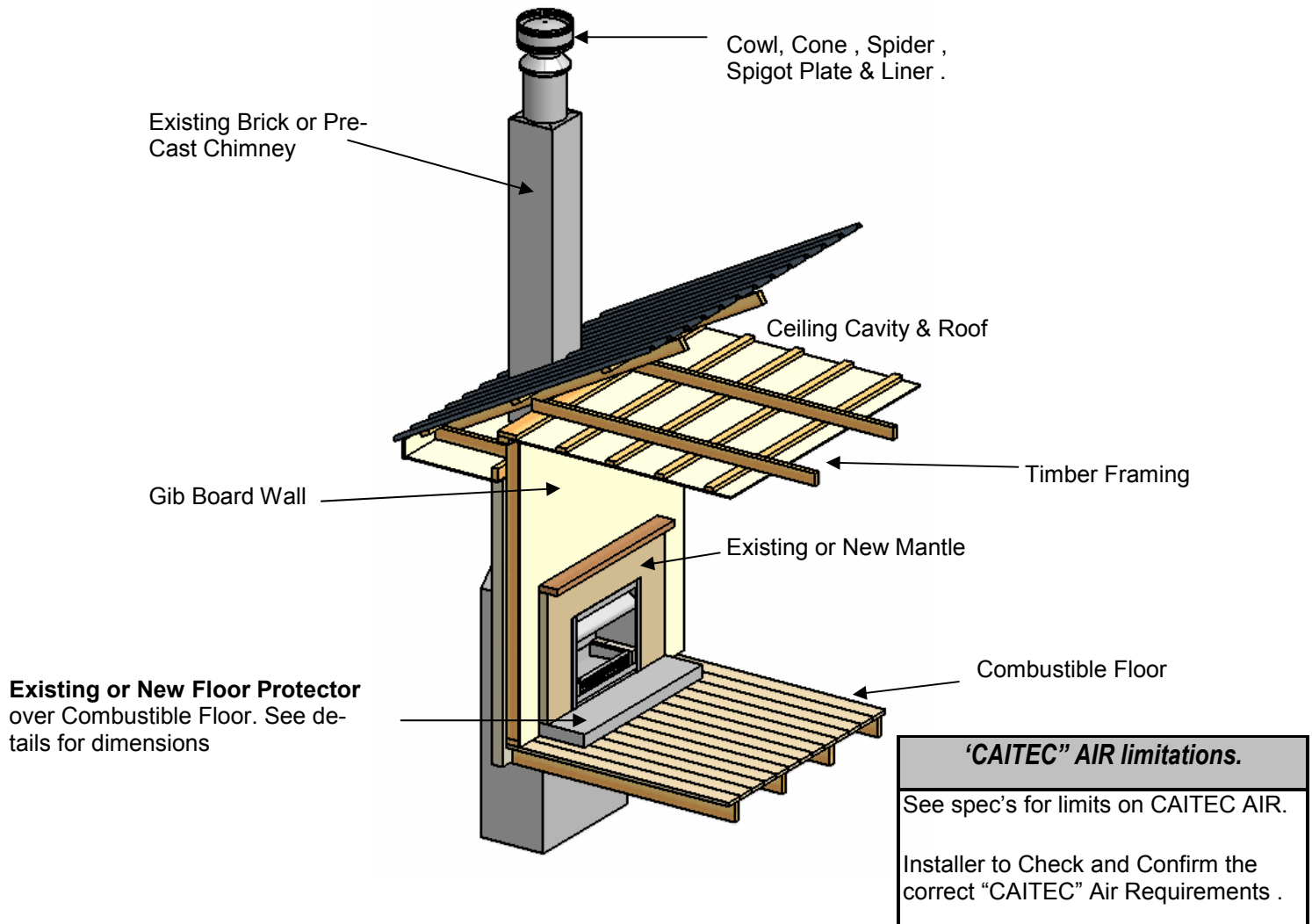

Visit www.warmington.co.nz for Spec's, DWG's and PDF uploads of Fires

Fire, Flue System and Instructions to Comply with ASNZS 2918:2001 /and Comply with appropriate Building Codes eg (C1 out break of fire).

Keep these Instructions for further reference.....Ensure that you have the correct and current Installation details for the Warmington Fire

Installation

The Warmington unit is to be Installed by a Certified Warmington Installer or an Approved NZHHA SFAIT Installation Technician .
See www.homeheat.co.nz/members for a Certified NZHHA SFAIT Installer in your area .

IMPORTANT

Read all the Instructions carefully before commencing the Installation. Failure to follow these instructions may result in a Fire Hazard and void the warranty

POINTS TO CONSIDER PRIOR TO INSTALLATION

Location of the Fire. Open fires are better located at one end of a room or area, as they project the heat away from their opening.

The Topography of the land .

The slope and position of the land in relation to the home has a bearing on how the wind will interact with the fire and flue system. Care needs to be taken to ensure that the flue termination is in the correct position to maximise performance.

The Prevailing Wind.

Care needs to be taken to ensure that the flue termination is in the correct position as wind and gusts that hits the flue and cowl system may overcome the cowl and draft back down the flue into the home. This can be a combination of down draft and high pressure.

Hearth and Plinth:

The Height of the Hearth off the Floor. The Finishing that is to be used on the Hearth is to be allowed for at the design stage.
Note : Ensure Air Intake at Base of Firebox is not blocked or restricted .

Positioning of the Flue System:

There is a maximum distance that an offset flue can be Installed . Reference to AS/NZS 2918:2001 .

Flue And Fire Clearance:

To be maintained to the Manufactures Instructions &/or Comply with appropriate Standards & Building Codes .

Pressure Differential, Venting & External Air into the Building :

All fires need air to burn and draw correctly, Kitchen Fans, Air Conditioning units, High Wind Zones, Naturally forming Draft spaces, can all have an effect on the pressure difference from inside the building to the outside. A lower pressure in the building may induce a draft down the flue system and back into the building causing the fire to smoke or spill into the building. **Care needs to be taken at the design and installation stage to adequately vent the building, or some mechanical system to ensure that there is always a neutral or positive pressure at the fire-place and a negative pressure at the flue outlet.** This will ensure that the draft in the flue system is always to the outside.

“CAITEC AIR” the limits and requirements. See details in these Spec's

Wind Noise:

You may encounter wind noise in some installations. It is recommended to use an enclosed chase with a chimney pot to help reduce noise. There will always be some noise from the flue systems of all fireplaces.

Using the Existing Chimney as the Flue System.

Ensure that the Existing Chimney Comply to the Appropriate Standards & Building Codes.

If the Chimney is not sound or needs repair then a Flue System may be required through the Existing Masonry Chimney. See Spec's in later pages.

The Integrity of the Chimney needs to be confirmed by the Installer at the time of Installation

INSTALLATION ORDER OF OPERATIONS

Prior to Construction and Installation

Important Notes:

Install to AS/NZS 2918:2001 by Certified NZHHA SFAIT Installer . See www.homeheat.co.nz .

The Fire must be Installed to Manufacture's Specifications.

All New Installations require an Application for Local Council Permit/Consent No (Repairs on Fire NOT Included.)

For Special Requirements concerning materials (Timber Mantles and Surrounds) within close proximity of Warmington products, please contact your local Warmington Technical Consultant .

Install Procedure by Certified “Warmington Installer” only , or see www.homeheat.co.nz go to “members & follow Instructions to Get a Certified NZHHA SFAIT Installer .

Stage 1: Removing Existing Fire (Brick Fire , Register Fire or Inbuilt .)

Important Note : Before Fire Removal , Check Outside & Inside of Chimney Chase for Structural Cracks etc . These will need to be Repaired .

Remove Old Flue System if Required & then remove Existing Fire from Chimney Chase.

Sweep Chimney & Clean entire chase out thoroughly . If a Ash Pit Exists at base of Fire , this will need to be sealed or covered over .

A new Plinth & Hearth may need to be Installed if necessary .

The Existing Mantle Opening may need to be Cut Out or Closed Down to accommodate the Warmington Firebox .

Stage 2: Installing Warmington Retro Firebox .

In most cases there will be a Gap around Firebox once in place . This needs to be filled in with a Non Combustible Material & with a 45 degree Chamfer at the Top for Ash to fall back into the Firebox , prior to Installing Fire . See following pages .

Install Firebox into Mantle Opening ensuring Firebox Flange ends up hard against Mantle Opening Face to create a good seal .

Secure Fire in place .

Stage 3: Installing Chimney Top Flashing System .

Remove any Existing Cowling or Top to leave a Flat Clean Surface .

Cut Spigot Plate Flashing to suit size of Chimney Top & secure level & in place with 6mm dynabolts or equivalent use Silicon to seal Spigot Plate . Note : The diameter of the Spigot Pipe should be equivalent to the Flue Size required for Fire type .

Mortar or Concrete over Spigot Plate .

Install Liner (cut to length) , Spider , Cone & Cowl . Also Bird Protection by Installer if required .

Ensure that the Warmington and flue system is swept annually or more frequently if required.

To Sweep Flue System and Firebox :

Cover Front of Fire with sheets.
Remove Cowl from Top of Chimney.
Sweep from the Top, Down the Flue.
Remove all Soot and Ash from Ashpan .
Ensure Cowl and Bird Protection is clean and replaced .

Visually Inspect Fireplace and Flue / Flashing System.

SELECTION OF THE SIZE OF FIRE TO FIT THE EXISTING CHIMNEY

The size of the fire and the size opening of the flue needs to be balanced for the fire to operate correctly.

The size of the Warmington firebox that is to be fitted to an existing masonry fire place, is generally set by the opening of the masonry flue system X and Y. (see box below).

Remedial work may need to be carried out to physically fit the firebox into the masonry opening, however this may limit the size of the fire that can be fitted.

Firebox		SI 440	SI 600	SI 700	SI 700T	SI 780	SI 780T	SI 900	SI 1100	Firebox can also be Custom Built to suit . (Modification cost will be Incurred) See this detail later in the spec's
Flue	K	200	200	200	200	200	200	250	300	
Flue Liner	L	300	300	300	300	300	300	350	400	

FIREBOX SELECTION

Remedial work may be necessary to fit the firebox into the masonry cavity, BUT the flue diameter 'K' will determine the size of the firebox.

The selected Firebox flue - (diameter "K") MUST be able to pass through the masonry chimney whether the flue pipe is being used, or the existing chimney is being used.

Always consult your Technical Representative for advice.

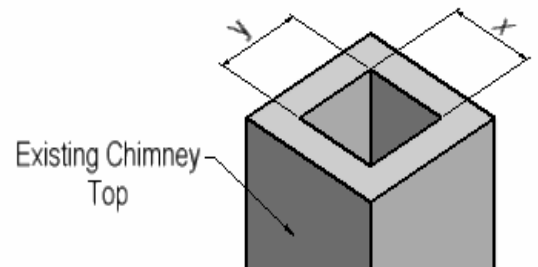

FLUE HEIGHT MINIMUM DETAILS

The Height of the masonry flue may need to be increased to obtain correct operation.

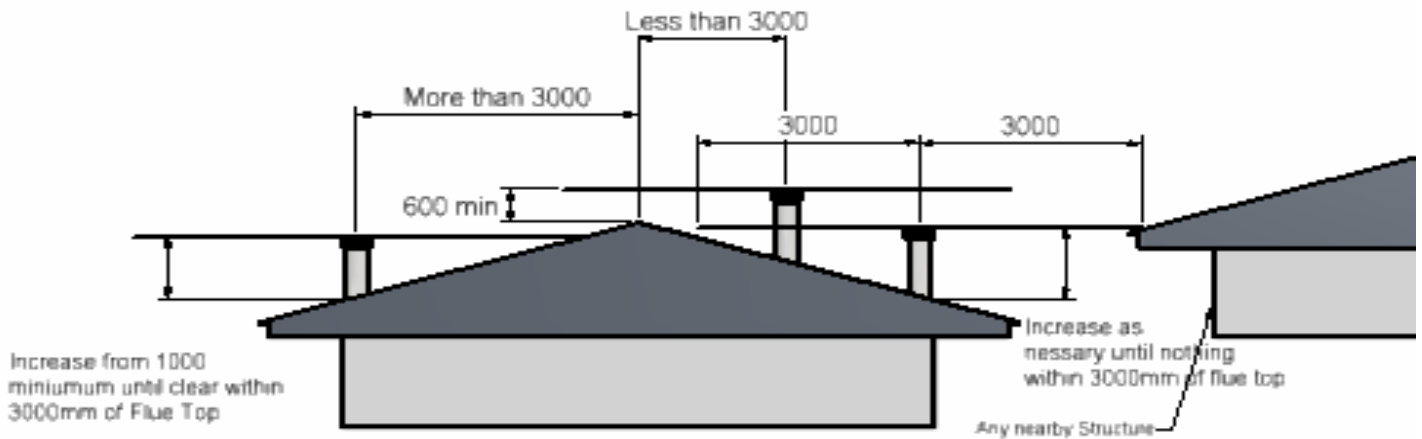

The Flue Penetration is to Comply to ASNZS 2918 : 2001

3D View

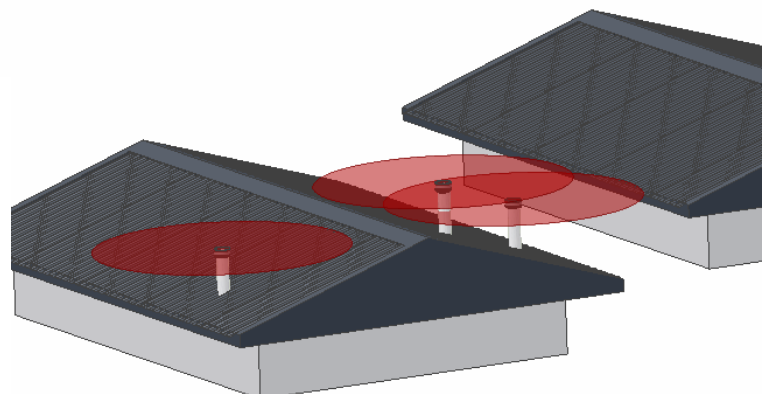

“CAITEC” and the BLANKING PLATE.

For fitment into existing chimneys the “CAITEC” is blanked off. This is due to the “CAITEC” and the flue being in the same flue system.

Additional “CAITEC” Air can be provided by venting the home as close to the fireplace as possible. See concept of external air supply.

If an adaptor and stainless steel flue system is fitted to the fire within the existing masonry chimney, the “CAITEC” Blanking Plate can be removed. The existing masonry fire place can be vented to an external air supply at the lowest level and the full advantages of “CAITEC” air will be provided.

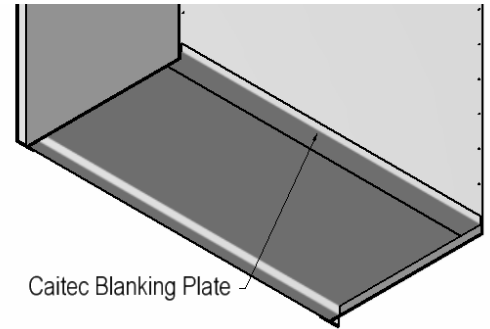

Caitec Blanking Plate

“Caitec” Weir Vent System (Concept Only)

“CAITEC” TECHONOLGY—ROOM AIR REPLACEMENT

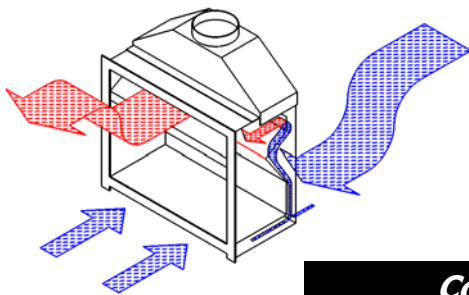

Caitec draws air from an External Air Source to ensure that Combustion Air that the Open Fire uses is replaced, maintaining the Home at a Constant Pressure Equilibrium, reducing the risk of Back Drafting.

Ensure that the Home is vented to Outside Fresh Air. 2 x 100mm Diameter vent are required (Or equivalent to that.)

Builder to supply External Air to the “Warmington Fire” . (Not Supplied)

Concept Drawings Only

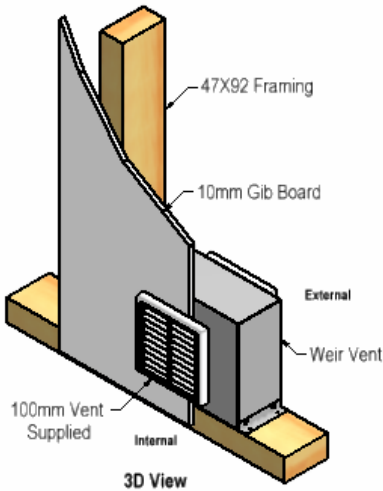

3D View

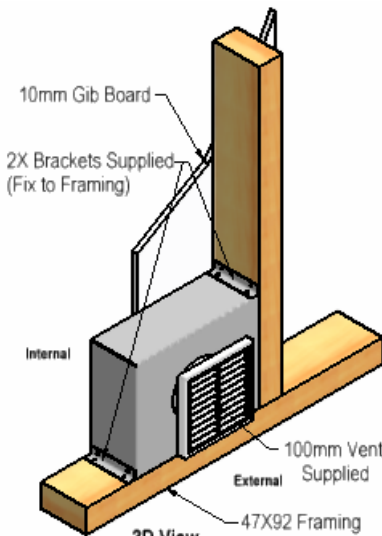

3D View

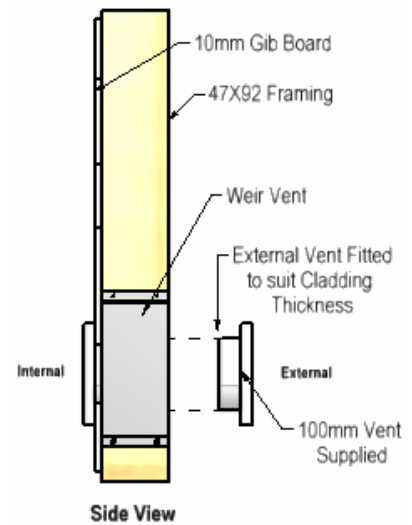

Side View

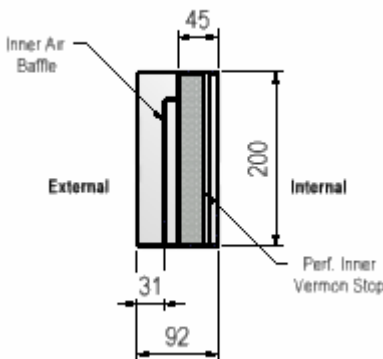

Side Section View

Important Note :
For Optimum Performance place “Caitec” Weir Vent System as close to Fireplace as possible

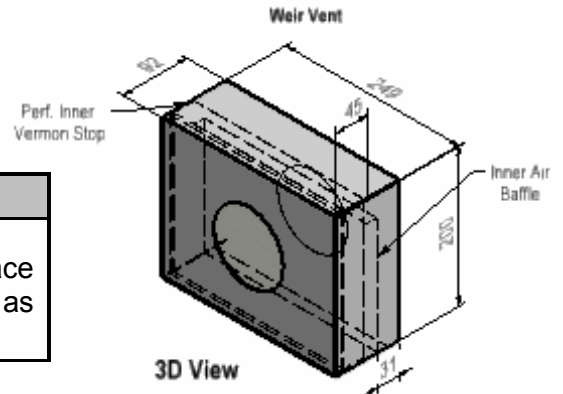

3D View

WARMINGTON FIREBOX DIMENSION

Firebox		SI 440	SI 600	SI 700	SI 700T	SI 780	SI 780T	SI 900	SI 1100	
Firebox Width	A	440	600	700	700	780	780	900	1100	
Firebox Height	B	600	600	600	650	600	680	750	800	
Firebox Depth	C	400	400	400	400	400	400	450	500	
Flange Width	D	490	650	750	750	830	830	950	1150	
Flange Height	E	625	625	625	675	625	705	775	825	
Alcove Width	F	460	620	720	720	800	800	920	1120	
Alcove Depth	G	410	410	410	410	410	410	460	510	
Hearth Projection	H	400	400	400	400	400	400	500	600	
Hearth Width	I	890	1050	1200	1200	1200	1200	1350	1550	
Spigot Plate Flue Dia		200	200	200	200	200	200	250	300	
Heat Output	kW						Tested			
Peak*		10	12	15	15	17	19	23	25	
Range*		5-8	8-10	10-12	10-12	11-12	12-14	13-15	14-16	

*Estimated unless stated otherwise.

Firebox can also be Custom Built to Suit . (Modification Cost will be Incurred)	Sizes mm
WIDTH A	mm
HEIGHT B	mm
DEPTH C	mm

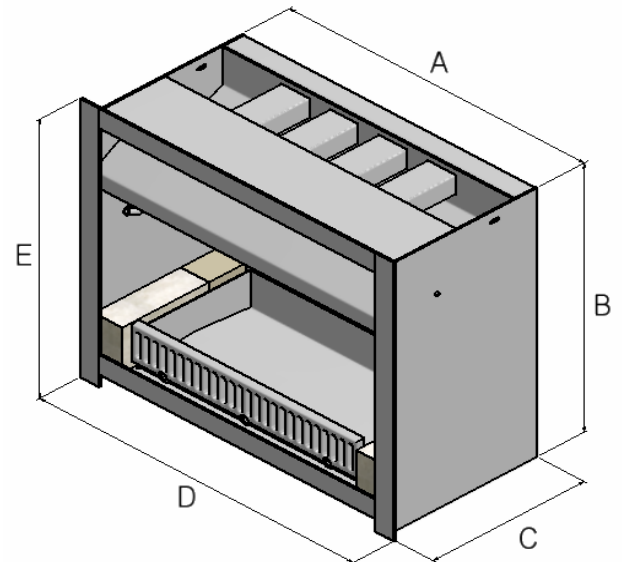
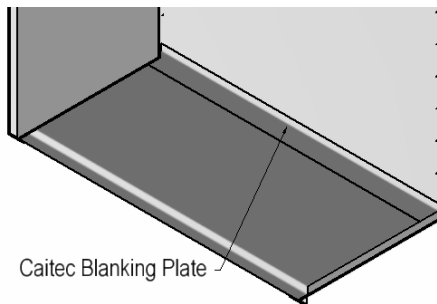

Note : Timber Framing
All Combustible Materials to be 50mm away from Chimney Structure in Accordance with Appropriate Building Codes .

Seismic Restraints
Secure Firebox in place with 2X Seismic Restraints . (Not Supplied) . Can be drilled through the Base of Fire , use 2X Dynabolts to secure .

Minimum Flue Height	
Top of Hearth to Top of Cowl	4600

Check List	Tick Box
Firebox	<input type="checkbox"/>
Ash pan	<input type="checkbox"/>
Bricks	<input type="checkbox"/>
Louvers	<input type="checkbox"/>
Badge	<input type="checkbox"/>
Damper Handle	<input type="checkbox"/>
Packed By	<input type="checkbox"/>

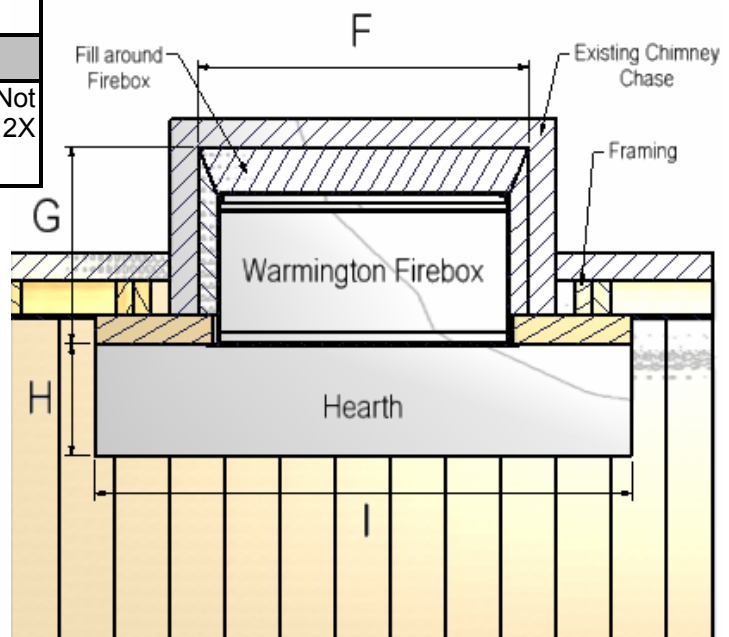

FIREBOX INSTALLATION

This is a general Installation guide only – Contact a “NZHHA Installer” for Installation Advice.
 See : www.homeheat.co.nz , choose “members” & pick your Area & Fire type (wood / Gas etc) this will provide you with a NZHHA Certified Installer (use the SFAIT Installers Only .)

Using the Existing Chimney as the Flue System.

Ensure that the existing chimney complies to the Appropriate Standards & Building Codes .

If the Chimney is not sound or needs repair then a Flue System may be required through the existing masonry chimney. See Spec’s in later pages .

The integrity of the chimney needs to be confirmed by the Installer at the time of Installation .

1. All the dimensions are millimetres.
2. Ensure that an Insulating Plinth is installed as per the Specifications. **Ensure that the plinth is elevated to allow for finishing on the Hearth. (See hearth and plinth details)**
3. Install Rockwool (Fire Resistant Insulation) or 75mm Hebel into cavity around firebox .
4. Fit the firebox into the cavity, the flange should have a tight seal around opening of existing cavity . Bolt the Firebox to the plinth or through the floor. This may require drilling through Fire Base under the ashpan & bolting in place . (Seismic Restraints).
5. Install the Retro Flue/Cowl System . (see page 7) .

HEARTH & PLINTH CONSTRUCTION DETAILS

IMPORTANT NOTE :

Note: Hearth and Plinth Construction.

For Combustible Flooring an Insulating Hearth and Plinth of 75mm is required.

Plinth to be offset above Hearth for the Hearth finishing (e.g. tiles / granite / plaster / etc)

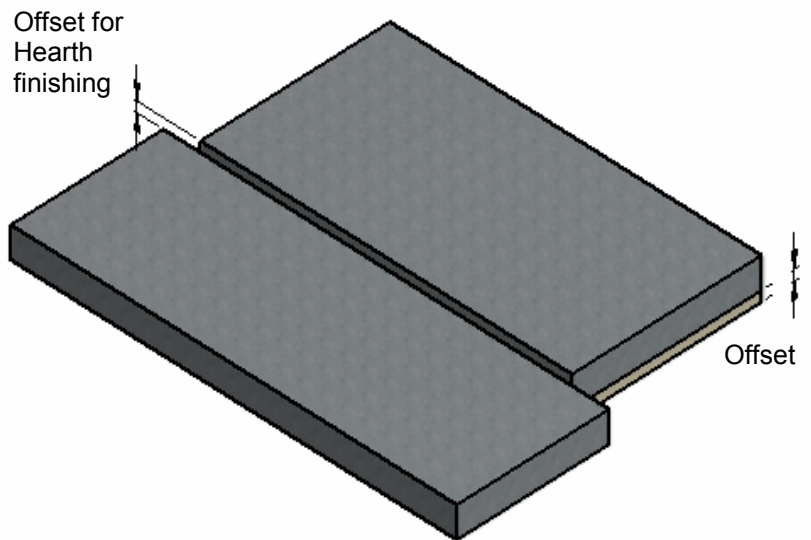

***Note: If Solid Plastering the Heat Cell Enclosure, it is recommended to use a Fibreglass Mesh with a Latex or Silicon Based Plaster to minimise the chance of the plaster cracking. (See your Solid Plasterer for correct materials and applications).**

Visit the Warmington Web Site for “Hebel” instruction (PDF Download).. www.warmington.co.nz

OPTION 1 : Using Existing Chimney as Flue

EXISTING FIREPLACE OPENING CLEARANCES

Firebox		SI 440	SI 600	SI 700	SI 700T	SI 780	SI 780T	SI 900	SI 1100
Window Width	J	460	620	720	720	800	800	920	1120
Window Height	K	610	610	610	660	610	690	760	810
Hearth Height	L	75	75	75	75	75	75	75	75

EXISTING FIREPLACE OPENING CLEARANCES

FIREBOX & CHIMNEY CHASE SECTION VIEW

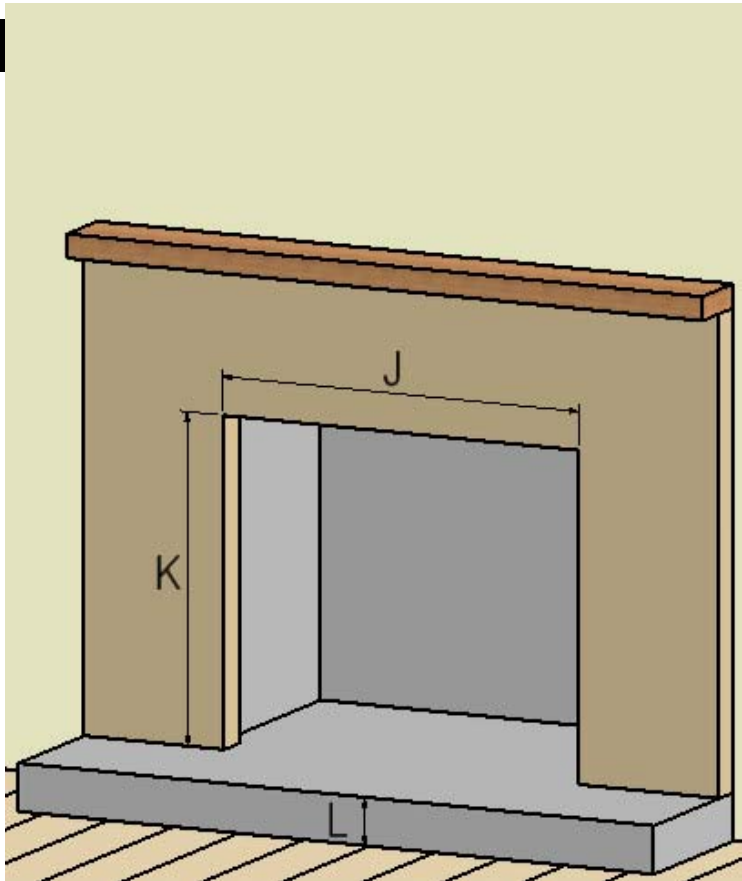
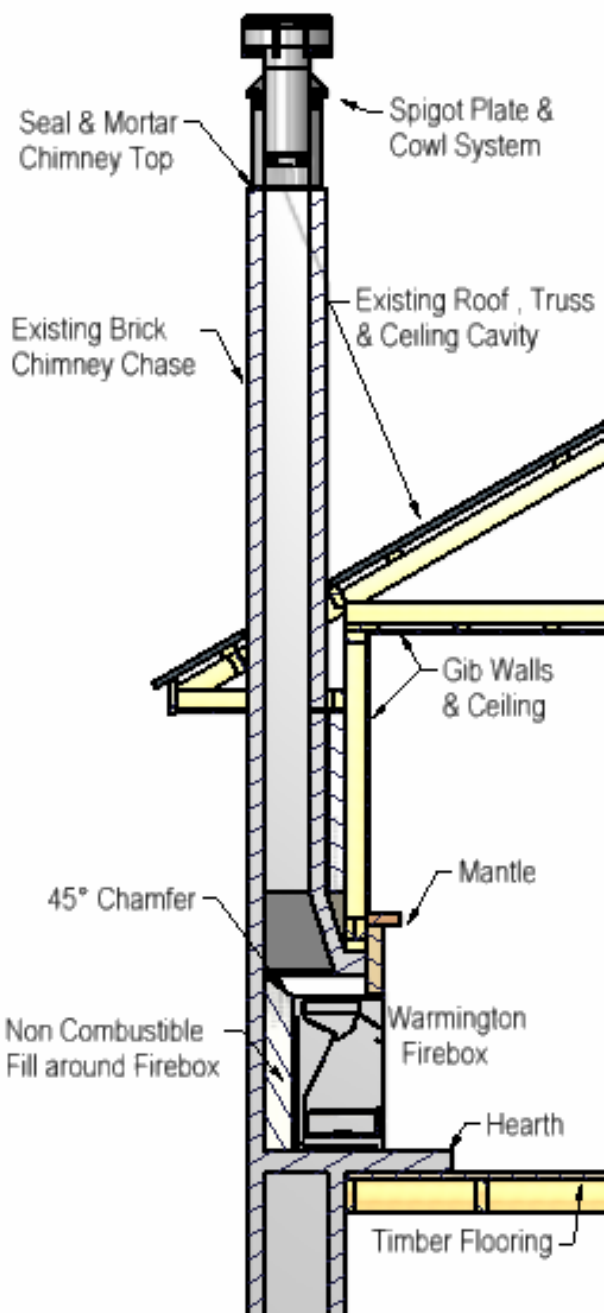

Note : Timber Framing (To be confirmed by the Installer on site)
 All Combustible Materials to be 50mm away from Chimney Structure .

'CAITEC' AIR (Installer to check)

For fitment into Existing chimneys the "CAITEC" is blanked off. This is due to the "CAITEC" and the flue being in the same flue system.
 Additional "CAITEC" Air can be provided by venting the home as close to the fireplace as possible. See concept of external air supply. (Not Supplied)

STEP 1 : REMOVE EXISTING FIREPLACE .

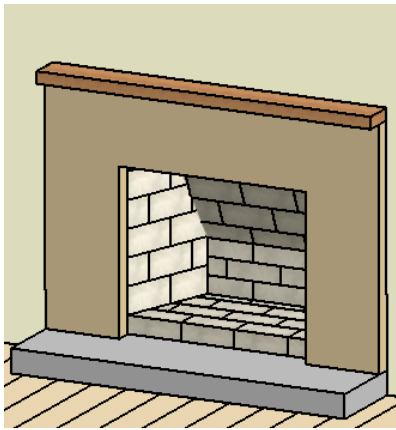

STEP 1a : Remove Fireplace
 Once the Main Chimney Structure has been assessed & Comply's to C1 Outbreak of Fire , remove existing Fireplace eg. Brick or Insert Firebox .

STEP 2 : MEASURE ALCOVE & HEARTH .

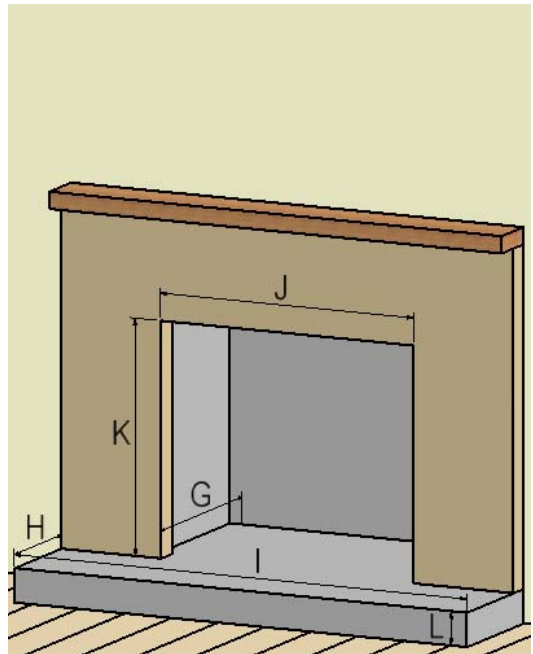

STEP 2 : Check Cavity Size
 Check Cavity Sizes as above to suit Firebox . In most cases Reducing or Enlarging these dimensions may be required to suit Firebox .

STEP 1b : Clean Out Cavity
 Once existing Brick or Insert Fireplace has been removed , Sweep out Chimney & remove all debri from Chimney Cavity .

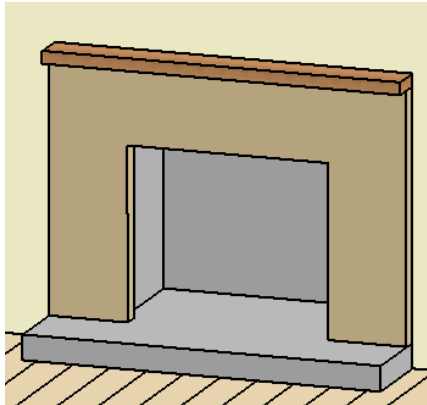

STEP 3 : FILL VOIDS AROUND FIREBOX .

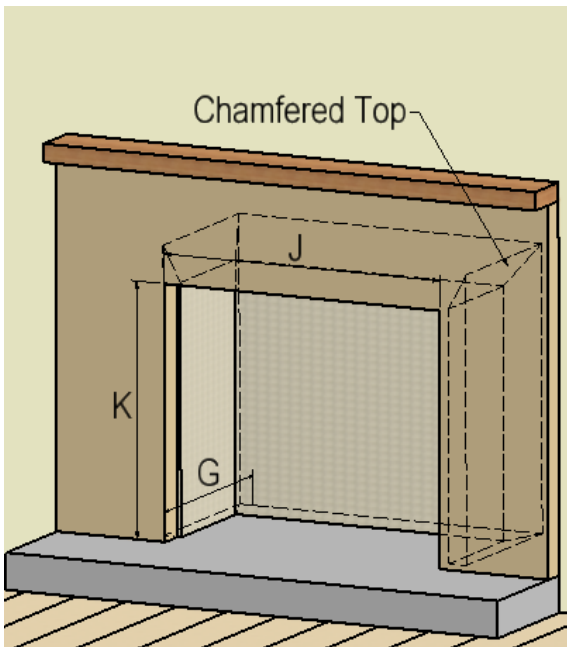

STEP 3 : Fill Voids Around Firebox
 Mark Out Firebox size on Plinth & Fill Void around Firebox with Non Combustible Material eg: Rockwool Insulation or Hebel Panels is Recommended , Chamfer Top of fill , this encourages Ash & Debris to fall back into Firebox when the Chimney is Swept .

STEP 4 : INSTALL FIREPLACE & SEAL .

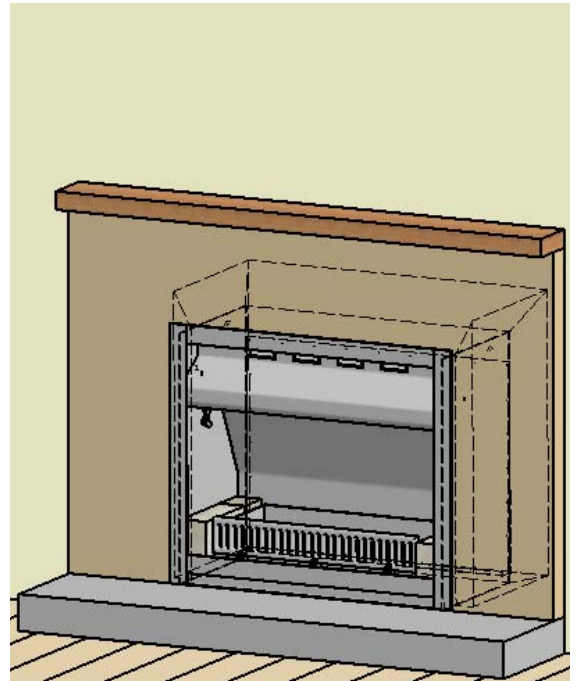

STEP 4 : Install Firebox in Place
 Slide Firebox in place ensuring a tight seal is created on inside of Firebox flange against mantle face heat resistant sealant may need to be used . Secure Firebox in place , this can be done by Drilling & Bolting through Base under Ash pan . Drill to suit .

SUGGESTED CHIMNEY CHASE FLASHING DETAILS (using existing chimney as the flue)

Using the Existing Chimney as the flue system.

Ensure that the Existing Chimney Comply's to the Appropriate Standards & Building Codes.

Retro Fit Chimney Flashing Detail

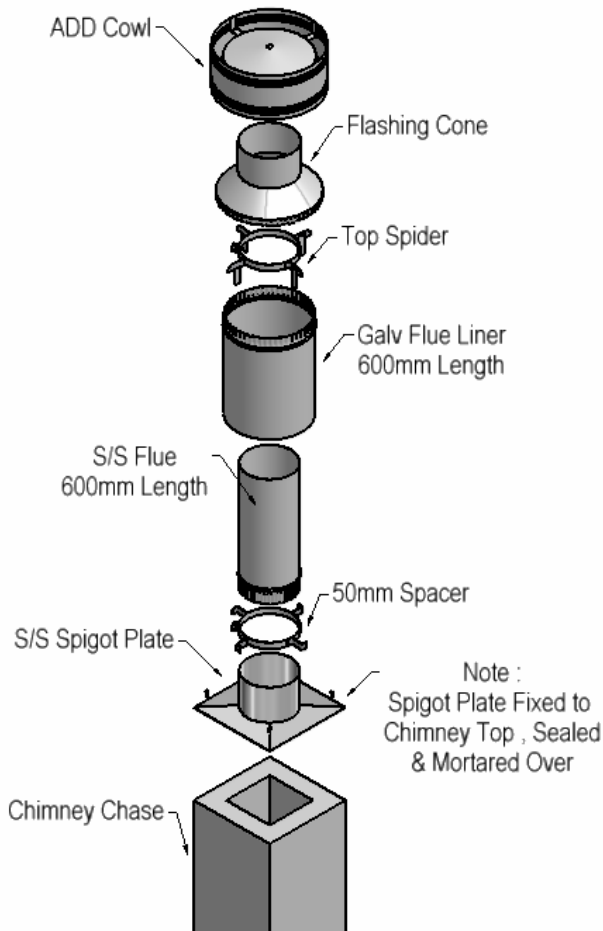

NOTE :

Chimney Top Flashing must be Installed in a Weather Proof manner . No Water should be able to get down Chimney Chase at any time .

SUGGESTED FLASHING & COWL SYSTEM INSTALLATION

Suggested Installation Details :

1. Remove Existing Cowl System & clean/remove any debris at top of Chimney Chase .
2. Cut the Spigot Plate 20mm+ smaller than Chimney Top if necessary , & dynabolt or fix in place centred on Chimney Top . Seal around Spigot with Sealant . Mortar Plaster over the Spigot Plate & create runoff for Water .
3. Rivet Flue to Spigot Plate in place & Install Spacer near bottom of Flue .
4. Cut Liner down to suit Cowl & Cone System . Use Steps below .
5. Bird Protection by Installer if necessary .

SETTING A.D.D COWL & FLASHING CONE HEIGHT

STEP 1

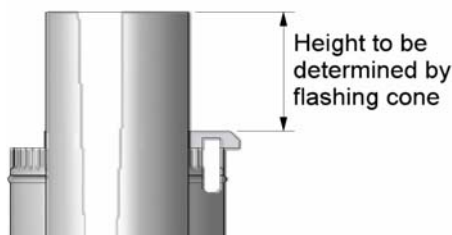

STEP 2

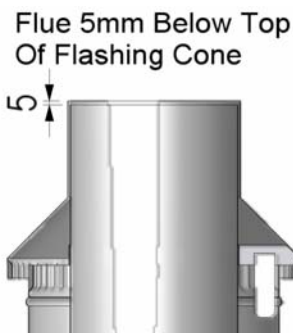

STEP 3



OPTION 2 : Using Offset Adaptor & Insert Fluekit

SUGGESTED CHIMNEY CHASE FLASHING DETAILS

Firebox		SI 440	SI 600	SI 700	SI 700T	SI 780	SI 780T	SI 900	SI 1100
Flue	K	200	200	200	200	200	200	250	300
Flue Liner	L	300	300	300	300	300	300	350	400

FIREBOX , OFFSET ADAPTOR & FLUE SYSTEM SECTION VIEW

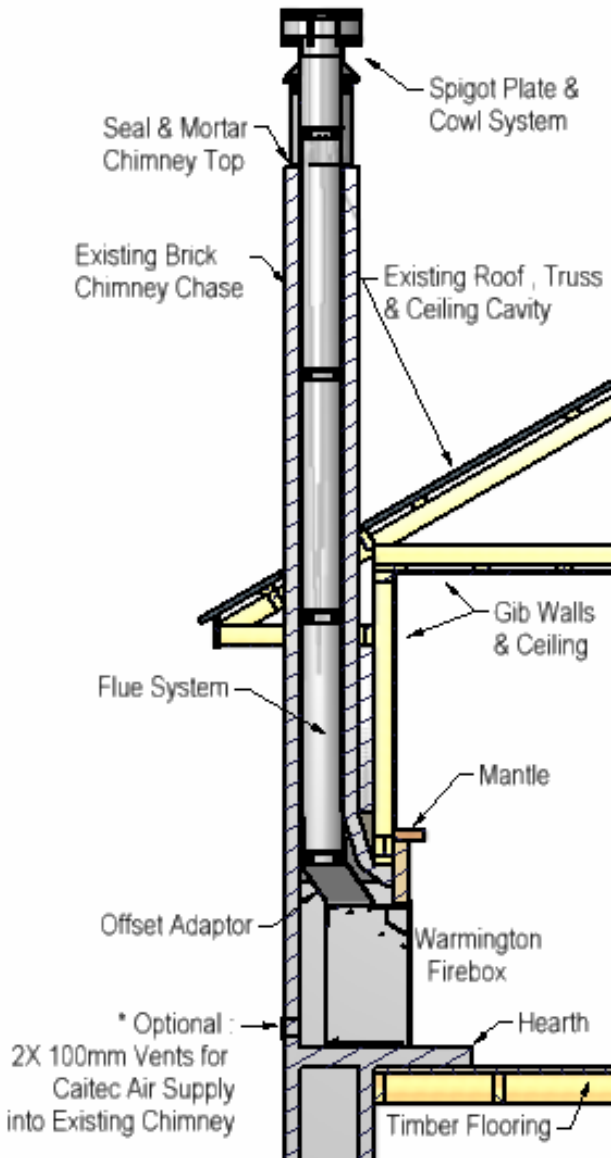

FLUE SIZE REQUIREMENTS

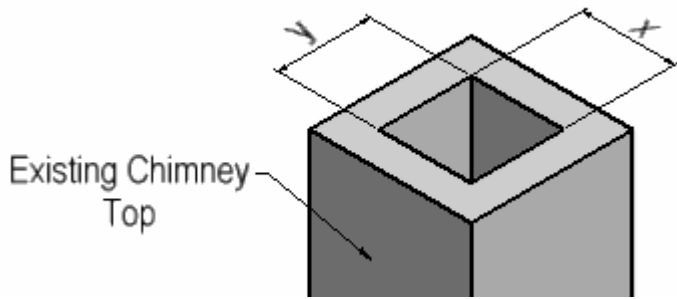

Installing a Flue System into the Existing Chimney.
 x & y measurements must be bigger than Flue Diameter K .

'CAITEC' AIR (Optional—by Installer)
 If an Adaptor and a Stainless Steel flue system is fitted to the fire within the existing masonry chimney, then the "CAITEC" Blanking Plate can be removed. The Existing masonry fire place can be vented to an external air supply at the lowest level and the full advantages of :CAITEC" air will be provided.

Installing a Flue System into the Existing Chimney.

Ensure that the Existing Chimney Complies to the Appropriate Standards & Building Codes.
 The integrity of the Chimney need to be confirmed by the Installer at the time of Installation .
 If the Chimney is not sound or needs repair then a Flue System may be required through the existing masonry chimney. Repair the Chimney so that it is structurally sound and prepare the Chimney for a Flue System .

OFFSET ADAPTOR

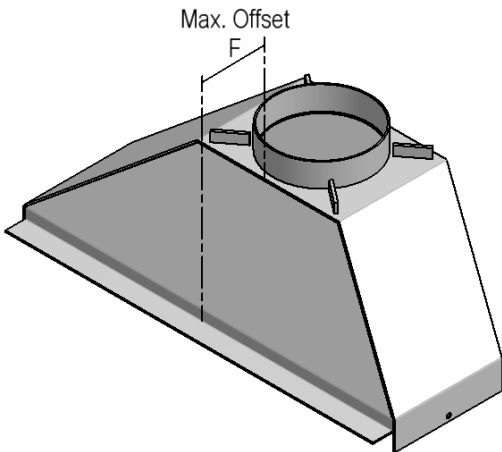

OFFSET in the Adaptor may be required

The Offset for the Adaptor must not exceed a Maximum Offset of Measurement "F". The Offset is taken from the original Flue Centre of the Fire System "J".

STANDARD ADAPTOR

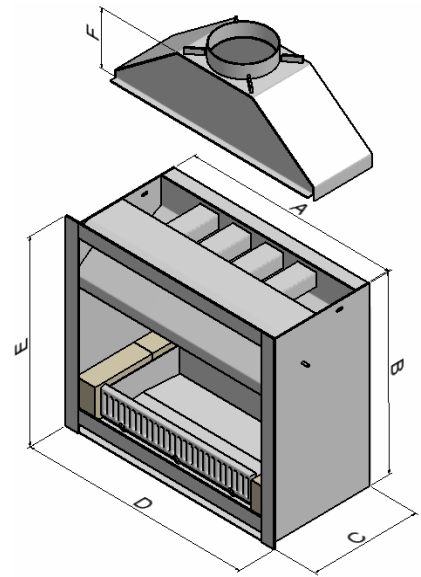

MEASURING FOR OFFSET ADAPTOR

Firebox		SI 440	SI 600	SI 700	SI 700T	SI 780	SI 780T	SI 900	SI 1100
Adaptor Height -Maximum Offset	F	210	210	210	210	210	210	270	270
Centre of Flue	J	290	290	290	290	290	290	310	340
Flue	K	200	200	200	200	200	200	250	300
Flue Liner	L	300	300	300	300	300	300	350	400

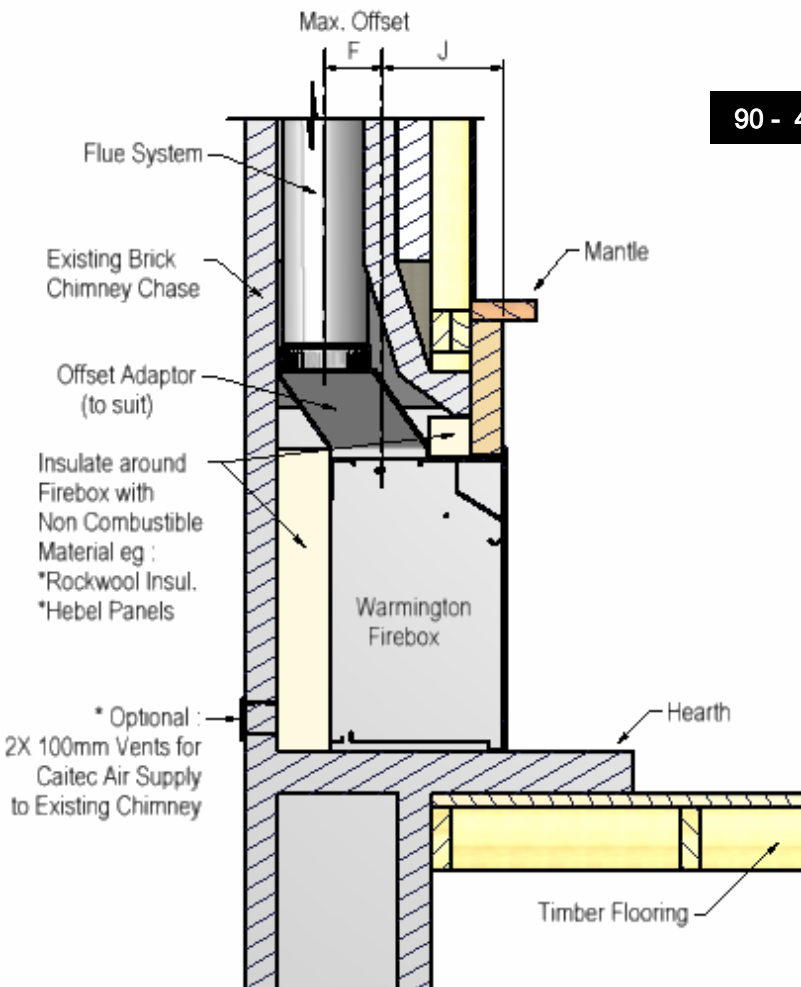

90 - 45 DEGREE MAX. OFFSET

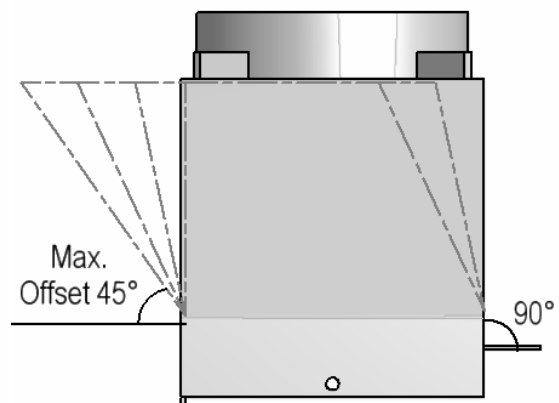

SIDE VIEW OF STANDARD ADAPTOR

Note: The maximum offset.

MEASURING FOR OFFSET ADAPTOR

Standard Flue Centre
 Measurements for Standard Flue Centre "J" in the table below from Firebox (inside) Flange to Adaptor Flue Centre .

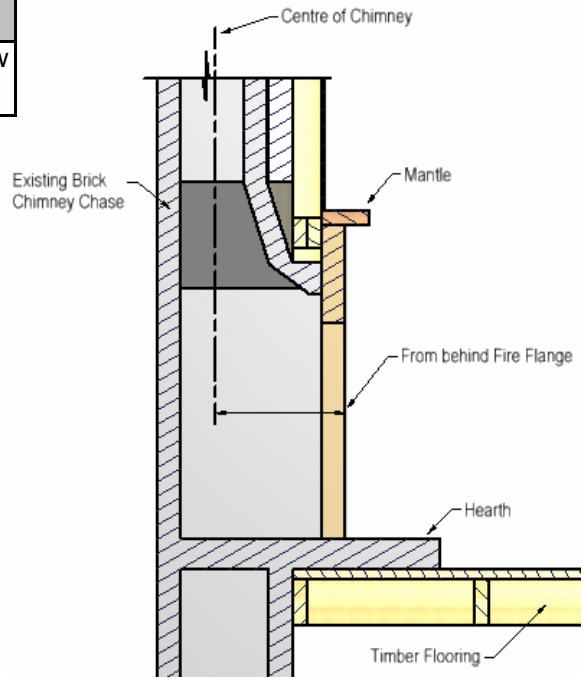
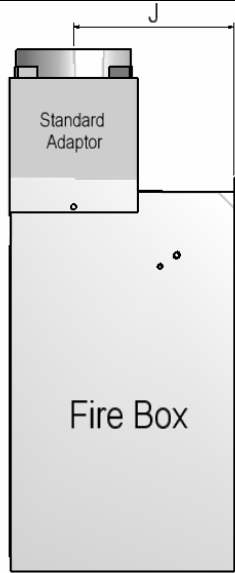

Firebox		SI 440	SI 600	SI 700	SI 700T	SI 780	SI 780T	SI 900	SI 1100
Adaptor Height -Maximum Offset	F	210	210	210	210	210	210	270	270
Centre of Flue	J	290	290	290	290	290	290	310	340
Flue	K	200	200	200	200	200	200	250	300
Flue Liner	L	300	300	300	300	300	300	350	400

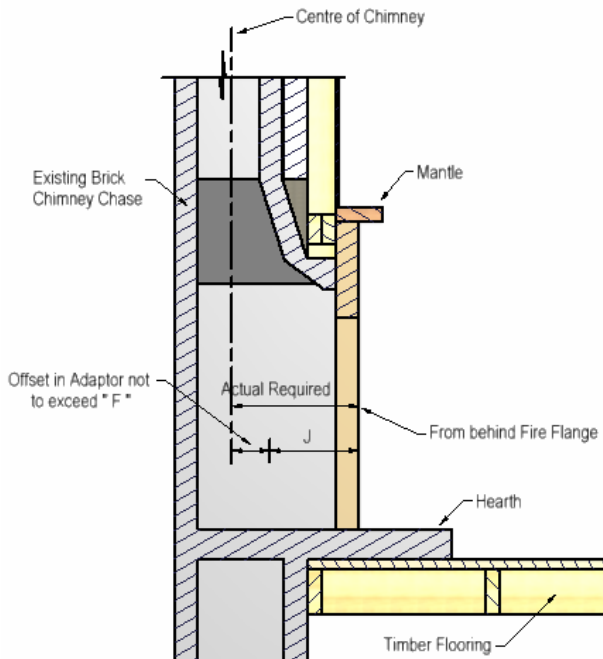

Chimney Chase Flue Centre

Measure Flue Centre from face of Mantle Opening (Inside of Firebox Flange) to the Chimney Chase Flue Centre.

NOTE: If the Warmington Fire is not finishing up to the Mantel face, then the Chimney Flue Centre is to be taken from behind the Warmington fires flange.

Offset Measurement Required

The Offset Required to Manufacture an Offset Adaptor is the difference between "J" & the "Actual Required" overall measurement . This must not exceed measurement "F" Adaptor Height on previous page .

COMBUSTIBLE MANTLE CLEARANCES

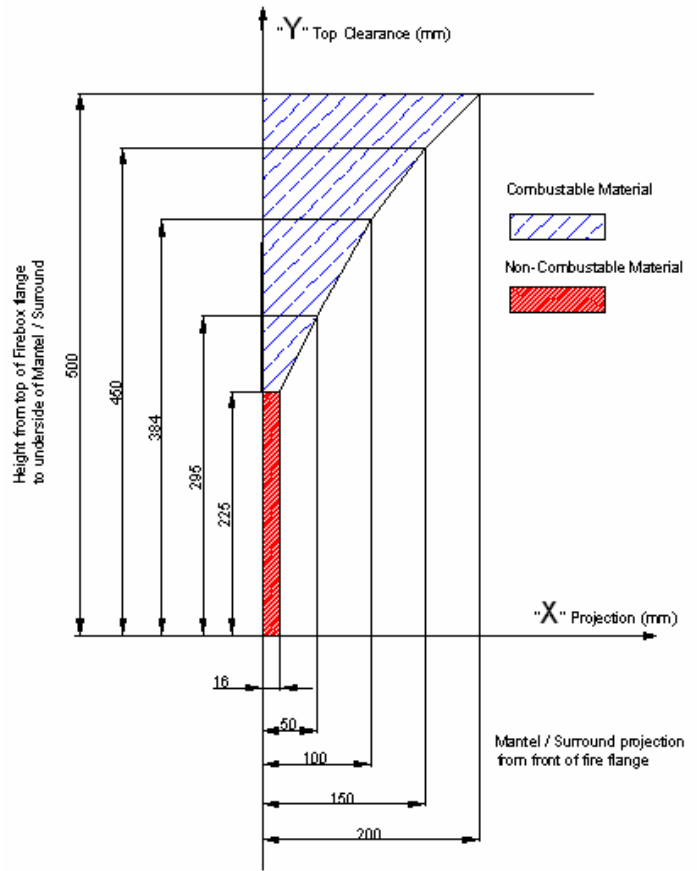
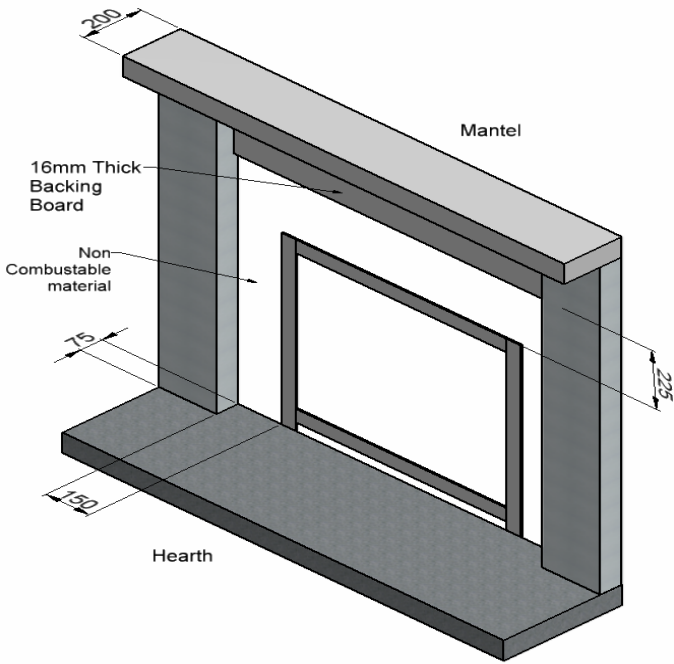

FLUE HEIGHT MINIMUM DETAILS

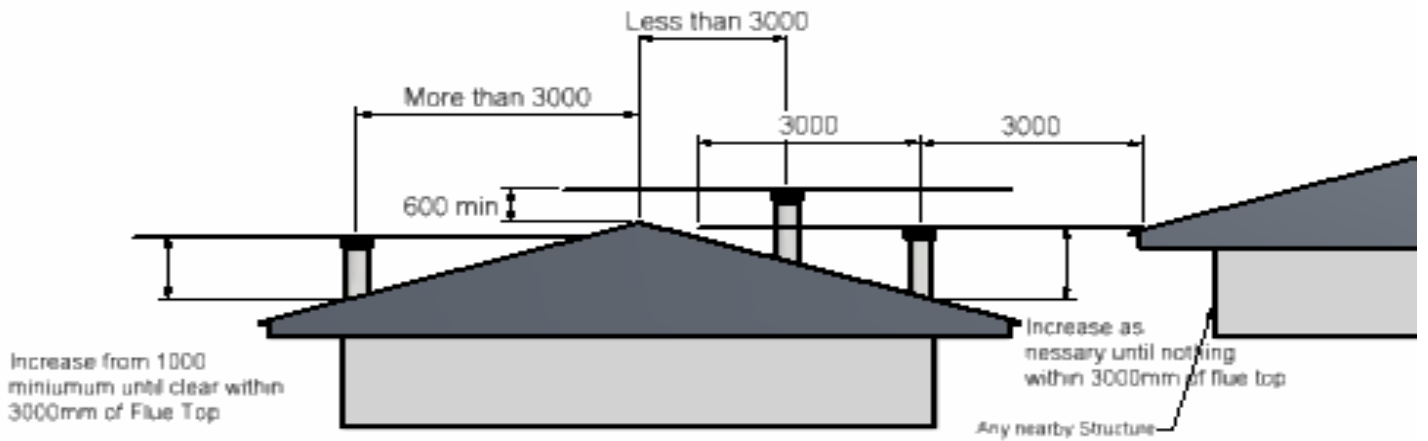

The Flue Penetration is to Comply to ASNZS 2918 : 2001

3D View

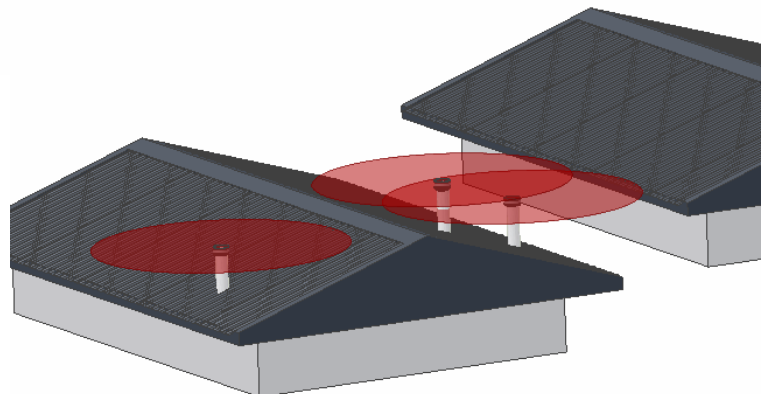

GENERAL NOTES : ASNZS 2918 : 2001**NOTES:**

- For the Fire operational and Maintenance Instructions visit www.warmington.co.nz and up load the PDF .
- Correct Installation must be maintained to comply with Warmington Warranty's .
- The Appliance and Flue System must be Installed in Accordance with ASNZS2918:2001 and the Appropriate Building codes .
- The Flue System and Fireplace is to be Swept Annually or more frequently if required .

WARNINGS:

- **WARNING; ANY MODIFICATION OF THE APPLIANCE THAT HAS NOT BEEN APPROVED IN WRITING BY THE TESTING AUTHORITY IS CONSIDERED AS BREACHING AS/NZS 4013 .**
- **WARNING; DO NOT USE FLAMMABLE LIQUIDS OR AEROSOLS TO START OR REKINDLE THE FIRE .**
- **WARNING; DO NOT USE FLAMMABLE LIQUIDS OR AEROSOLS IN THE VICINITY OF THIS APPLIANCE WHEN IT IS OPERATING .**
- **WARNING; DO NOT STORE FUEL WITHIN HEATER INSTALLATION CLEARANCES .**
- **WARNING; WHEN OPERATION THIS APPLIANCE AS AN OPEN FIRE USE A SPARK SCREEN .**
- **CAUTION:** THIS APPLIANCE SHOULD BE MAINTAINED AND OPERATED AT ALL TIMES IN ACCORDANCE WITH THESE INSTRUCTIONS
- **CAUTION:** THE USE OF SOME TYPES OF PRESERVATIVE-TREATED WOOD AS A FUEL CAN BE HAZARDOUS.

Model	Estimated KW	Average KW
440	10	6
600	12	8
700	15	10
700T	15	10
780	17	11
780T	Tested 19	12
900	23	13
1100	25	14

NOTE: For Operation instruction down load from the web site
www.warmington.co.nz



Industries 1994 LTD
PO Box 58652 Greenmount, Auckland www.warmington.co.nz