

Warmington Open Fire's

Maintenance and Operating Instructions



How to light and maintain a Open wood fire.

POINTS TO CONSIDER PRIOR TO INSTALLATION

- **Location of the fire in the home.** The position of the fire will have an effect on the distribution of the heat throughout the home. Open fires are better located at one end of a room as they project the heat away from their opening.
- **External air supply.** See the CAITEC detail. The reason for the supply of external air into the home is to reintroduce the air that has been used in the combustion process of the fire. This keeps the home at an equal pressure to the outside. Kitchen extractor fans can cause a large pressure difference in the home, and in some conditions can cause the fireplace to smoke towards the extractor fan. Kitchen fans may require their own external air supply.
- **Venting to the cavity.** This air is to allow the cavity to vent the warm air. This warm air helps keep the fire and flue system from getting too cold. If the flue and fire get too cold the system may soot often and require cleaning.
- **The Topography of the land.** The slope and position of the land in relation to the home has a bearing on how the wind will interact with the fire and flue system. Care need to be taken to ensure that the flue termination is in the correct position to maximize performance.
- **The prevailing wind.** Care needs to be taken to ensure that the flue termination is in the correct position as wind gusts that hit the flue and cowl system, may overcome the cowl and draft back down the flue into the home. This can be a combination of down draft and high pressure.
- **Hearth and plinth:** The height of the hearth and plinth from the floor, and the finishing that is to be used on the hearth is to be allowed for at the design stage.
- **Positioning of the Flue system:** There is a maximum distance that an offset flue can be installed. Reference to AS/NZS : 2918: 2001 para 4.1.
- **Flue and Fire Clearance:** To be maintained to the Manufacturer's Instructions.

CORRECT OPERATION OF WOOD BURNING HEATING APPLIANCES

Burn Control and Operation of your Warmington Fire.

Simply by operating your wood heater correctly, you can improve efficiency and reduce air pollution.

The wisdom and skills needed to operate a wood heater effectively do not come to us automatically just because we own a wood heater and live in a cold climate. They must be acquired and applied regularly to get them right. A great deal has been learned since the era of modern wood burning began in the mid 1970s. Extensive research has improved the internal design of wood heaters, making them easier to operate efficiently. Research has also provided a better understanding of how to operate wood heaters efficiently so that outdoor air pollution is reduced and indoor smoke spillage is prevented. By practicing and mastering techniques offered here, you will reduce the amount of wood you burn to heat your home, and increase the convenience and pleasure of wood burning.

STARTING A NEW FIRE

Always follow the instructions supplied with the new wood heater.

To start and maintain a good fire you will need the following ingredients:

- A packet of firelighters (optional)
- A small quantity of newspaper (do not use coloured or coated paper)
- A quantity of finely split, dry soft wood kindling in a variety of sizes; and
- Seasoned firewood split into a range of piece sizes.

For ease of operation and optimum efficiency follow these few guidelines:

Open Fires: The air supply for an open fire is through the front and is not controllable. An open fire will take the air, as it requires it. Ensure that the damper is open fully allowing clear passage for the smoke to discharge.

“Warmington’s CAITEC” room replacement air

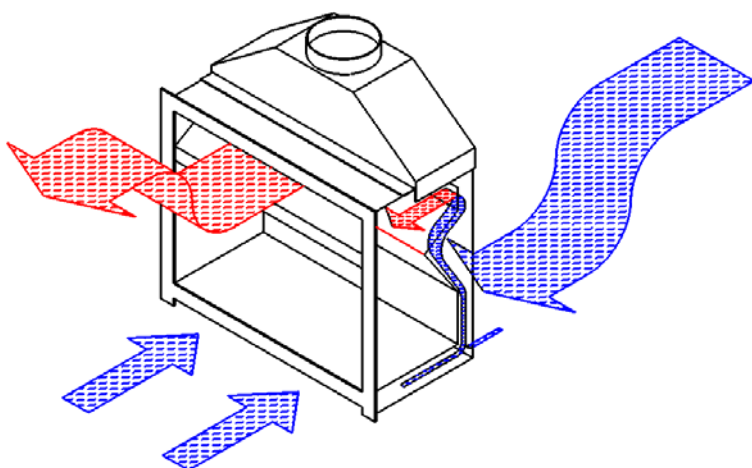

Caitec draws air from an external air source to ensure that the open fire has pre-heated combustion air, maximizing efficiency while maintaining the home at constant pressure equilibrium, reducing the risk of back drafting. Ensure that the cavity is vented to Outside fresh Air and the Warmington will take care of the rest. 2 x 100mm Diameter vent are required (or equivalent to that.)



Next crumple half a dozen sheets of newspaper and put them in the firebox. The amount of newspaper you need will depend on the firebox size, and the dryness and fineness of the kindling you are using. Many people make the mistake of not using enough newspaper. Be generous with the newspaper and you will have more success. Putting some firelighters under the newspaper can also help sustain firebox temperature until the wood is burning.

On top of the paper place 10 to 15 pieces of finely split, dry kindling. Softwoods, such as cedar and pine, make good kindling. Ideally, the kindling should be placed on and behind the newspaper. It is also a good idea to add two or three very small pieces of firewood to the kindling load before lighting.

For **Open Fires**, set the newspaper alight around the base of the fire and allow the fire to take. Ensure that the damper is in the fully **open** position when lighting the fire.

The goal when lighting a wood fire is to use only one match and to achieve rapid ignition of the load. After practicing this procedure a few times, you will learn how to establish a good, smoke free, hot fire. When the flames from the kindling load just begin to subside, add several **small** pieces of firewood. Try to avoid smothering the fire with the new pieces. Placing the pieces on and behind the burning kindling can help prevent smothering.

Note: You may notice a faint smell on the first light of the fire. This is the paint coat curing- this will soon vanish. See details in these instructions below for curing the paint coating.

SOME OTHER USEFUL TIPS

Full load geometry: Small pieces of firewood arranged loosely in a crisscross pattern burn quickly because the combustion air can reach all the pieces at once. Larger pieces placed a little more compactly burn more slowly. Never add just one or two pieces of wood to a fire. Three or more pieces are needed to form a sheltered pocket of glowing coals that reflect heat toward each other and sustain the fire.

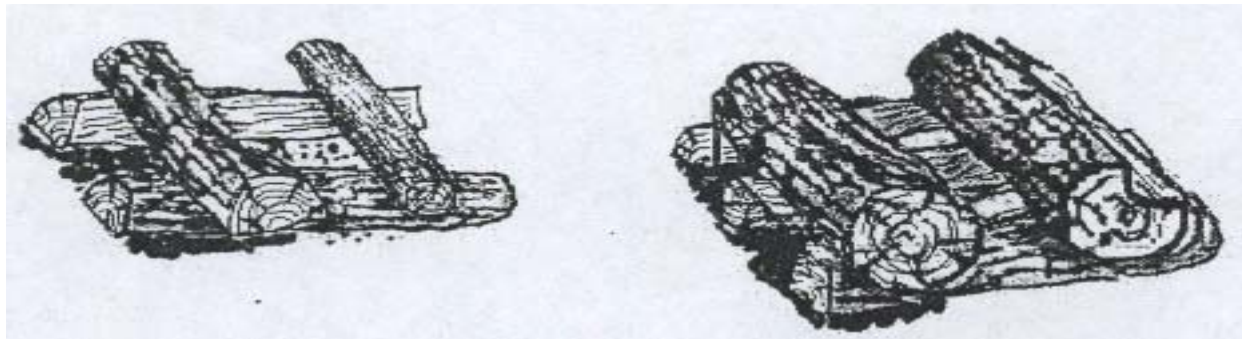

A SMALL-STACKED FUEL LOAD
Good for short-duration fires.

A LARGE-STACKED FUEL LOAD
Good for extended burning cycles.

Fires in cycles: Don't expect perfectly steady heat output from the fire. Wood heaters burn best in cycles. A cycle is the time between the ignition of a load of seasoned timber and its reduction to charcoal through combustion. Each cycle should provide between four and eight hours of heating, depending on how much wood was used and how much heat is needed. Plan the firing cycles around your household routine.

Removing ashes

When you use your fire for a few weeks you will find ashes accumulate in the firebox. The ashes can be removed easily from the ash pan when it is completely out. The amount of charcoal in the ash is often a good indicator of how well you are operating the heater. If there is no charcoal and only very fine ash then you are doing an excellent job. Warmington wood-burning appliances work best when a small amount of ash is left approximately 25mm deep in the firebox after cleaning, this aids with stable burning. The ash should be placed in a non-combustible container with a tightly fitting lid and moved outdoors immediately to a location clear of combustible materials.

When You Have mastered the Techniques for efficient wood burning, Here is what you should see:

When wood burns it should be flaming until only charcoal remains. If there are no flames, something is wrong.

If there are firebricks in the firebox, they should be tan in colour, never black, Steel or cast iron parts in the firebox should be light brown, never black and shiny.

With seasoned wood, correct air settings and proper loading arrangement you should expect instant ignition of a new load of wood – the bottom pieces should be flaming by the time the door is closed.

The exhaust coming from the top of the flue system should be clear or white. A plume of blue or grey smoke indicates smouldering, poor combustion, air pollution and probably low operating temperatures. This means your fire is not only inefficient but also contributing to air pollution.

SOME COMMON QUESTIONS

Smoke Spillage: A survey of households that use wood for heating showed that a large majority of users had experienced smoke spillage from their appliances at least once. These episodes of smoke spillage can be reduced or eliminated through proper appliance operation. The smell of wood smoke inside your home is a sign that the wood heating system is not functioning properly. The smoke contains harmful air pollutants that can be irritating or even dangerous. Properly designed, installed and operated wood-burning appliances do not spill smoke into the house. There are three main reasons why some wood burning appliances smoke:

Bad flue system design: There are design characteristics that can make a wood heater more likely to spill smoke. Most of these characteristics result in low flue temperatures and low draft. For example, flue systems that run up the outside wall of the house and are not correctly insulated can rob the heat from the flue and produce very little draft. Each elbow in the flue pipe assembly slows down the flow of gases and causes a small restriction to flow. When a flue system includes more than one elbow, the restriction can be enough to cause spillage.

Extreme negative pressure in the house: Energy efficiency practices and new building code rules are making our houses more and more airtight. This makes the houses energy efficient, but also makes them more sensitive to depressurisation when air is exhausted from the house. Large, fan forced exhaust ventilators, like down-draft-type kitchen stove exhausts, can cause extreme negative pressure in the house when they are operating. Because new houses are tightly sealed, there are few holes to allow replacement air to enter, and the house pressure becomes negative. This negative pressure works against flue system draft.

In severe cases, the negative pressure in the house overcomes the flue system draft and the appliance begins to spill smoke, especially when a fire is started or when it dies down to coals. To prevent this extreme depressurisation, one option is to link a large exhaust ventilator to a make-up air system which forces air into the home to replace the exhausted air.

Improper appliance firing technique: When a wood fire is starved for air it smoulders, producing a relatively cool, smoky fire. The temperatures throughout the system are low. During a smouldering fire, the flue system will not be receiving the hot gas it needs to produce strong draft. When the appliance door is opened, smoke will spill into the room. A smouldering fire is the single most common reason for smoke spillage and totally unnecessary. By using the suggestions on proper firing technique earlier in this document, you will be able to avoid these smouldering fires.



PAINT AND THE CARE OF

Information on the paint coating is on the web site: http://www.forrestpaint.com/stovebright/troubleshooting_guide1.html

When lighting the fire for the first time

Ventilate the house during the first three times the stove is used. The paint on the stove will give off smoke heavy with carbon dioxide and has an odour. Without adequate ventilation, concentrations of smoke could irritate, or be upsetting. Babies, small children, pregnant women and pets should not be in the area due to these carbon dioxide fumes causing an imbalance in the air quality. Open doors and windows and use a fan if necessary. After these initial burns, the paint will be set and there should be no more smoke.

Don't touch the surface. It will be soft and gummy during this phase. Once set, it will not be soft again.

Most stoves stop smoking after 3 burns. The first two should be at 250F (121C) for 20 minutes or about half a normal fire. Do not let the stove cool down significantly between burns. The last fire should be between 500F (260C) and 700F (370C) for at least 45 minutes. The point being, operate slowly without a hot fire. If the stove gets too hot, too quickly, the paint will crack. Owners of stoves that have a door gasket should check with the stove dealer about leaving the door ajar during this process to keep the gasket from sticking to the jam.

Stoves with a cooler surface temperature and those that were previously painted with another colour will take longer to set.

This process can usually be observed by the effect of the paint turning flat as the heat radiates out from hotter parts of the stove.

Summary on Setting High Temp Pain:

Read Stove Manufacturer instructions

Babies, small children, pregnant women and pets should leave the area during the paint setting phase.

Ventilate well

Paint surface will look "wet" and will smoke

Do not touch paint surface during this process

Set slowly with successive burns

Call your dealer with any questions

WARNING: ANY MODIFICATION OF THE APPLIANCE THAT HAS NOT BEEN APPROVED IN WRITING BY THE TESTING AUTHORITY IS CONSIDERED AS BREACHING AS/NZS 4013.

WARNING; DO NOT USE FLAMMABLE LIQUIDS OR AEROSOLS TO START OR REKINDLE THE FIRE.

WARNING: DO NOT USE FLAMMABLE LIQUIDS OR AEROSOLS IN THE VICINITY OF THIS APPLIANCE WHEN IT IS OPERATING.

WARNING: DO NOT STORE FUEL WITHIN HEATER INSTALLATION CLEARANCES.

WARNING: WHEN OPERATING THIS APPLIANCE AS AN OPEN FIRE USE A SPARK GUARD WHEN AWAY FROM THE FIRE.

CAUTION: THIS APPLIANCE SHOULD BE MAINTAINED AND OPERATED AT ALL TIMES IN ACCORDANCE WITH THESE INSTRUCTIONS

CAUTION: THE USE OF SOME TYPES OF PRESERVATIVE-TREATED WOOD AS A FUEL CAN BE HAZARDOUS.

CARE OF WOOD

Storing/Drying Fuel

Use dry timber, preferably cut the previous year.

PURCHASING THE FIREWOOD

The quality of the firewood can have a dramatic effect on the efficiency and operation of the heater. The main factors that affect the burning characteristics of firewood are moisture content, tree species and piece size.

The moisture content of the wood affects the rate at which burns and the efficiency of combustion. When trees are cut, the wood moisture content ranges between 35 and 60 percent by weight. If you attempt to burn wood this wet, it will be hard to ignite, slow to burn and will hiss and sizzle in the firebox. So much energy will be consumed in boiling off the excess water that the efficiency of combustion and the heat to your home will be low, condensation and corrosion may be occurring in the flue and smoke may be causing problems to your neighbours. Properly seasoned wood ignites readily and burns efficiently.

Firewood should be cut and split in the early spring and stacked under cover, with good ventilation, to be ready for burning when required.

Look for checks or cracks in the end grain as a sign of dry wood. The stacks of firewood should be in an open area so that air can circulate through them. During the summer, as warm breezes flow through the stacks, carrying away the evaporating water, the moisture content of the wood will fall to around 20 percent. At this moisture content the wood is ready for burning.

Although the energy content of dry wood per kilogram is almost the same regardless of species, softwoods and hardwoods burn differently because of differences in density. Softwoods, such as pine, are less dense than hardwoods like gums, Manuka or ironbark. A denser wood will produce a longer-lasting coal bed, while a less dense wood will bring a fire to an optimum burning temperature more quickly.

The size of the firewood pieces affects the rate of combustion. Larger pieces ignite and release their energy more slowly than small pieces. Smaller pieces are better for short, hot fires and larger pieces are preferable for extended firing cycles. In general, commercial firewood dealers produce firewood in larger pieces than modern wood-burning appliances can handle. It is often necessary to split some of the wood again before using it.

Firewood harvesting can have an effect on native woodlands and a variety of threatened species. Dead standing and fallen timber provides habitat for numerous species of animals and birds. Wood heater operators should be encouraged to be sensitive about the source of their firewood. If collecting it privately, operators should leave some dead wood behind as it provides habitat for birds and animals.

NOTES:

Construction

The fires are constructed from 4mm-5mm- and 3.2mm steel plate.

Finish

High temperature steel parts are finished with a matt black high temperature paint designed to withstand the rigors of normal combustion.

Testing

The Warmington has been tested and approved to AS/NZS 2918:2001 specifications for solid fuel burning heaters.

Flue System

The installation and construction of the flue system must comply with AS/NZS 2918. The Warmington Open fires require a Warmington Tested and approved flue system only, as tested to AS/NZS 2918. The tested flue system should not be modified in any way without the written approval of the manufacturer. Any additional flue components to the flue system must comply with AS/NZS 2918.

Floor Protection

Floor protectors are normally designed to suit each individual "setting". The installation and construction of the floor protector must comply with AS/NZS 2918. The Warmington requires an "Insulating hearth" and an "Insulating Plinth" (floor Protector) as outlined in the specifications.

MAINTENANCE

Maintenance **The Chimney is to be cleaned annually or more frequently if required.**

Chimney Maintenance:

Use a chimney brush to clean the flue from the top down. Remove soot/ash from the firebox.

To sweep flue and firebox:

- 1) Open damper fully.
- 2) Cover front of fire with sheets.
- 3) Remove cowl from top of chimney.
- 4) Sweep from the top, down the flue.
Remove all soot and ash.
Ensure cowl and bird protection is clean and replaced

Visually inspect fireplace and flue system.

To comply with manufacturers warranty the firebox, adaptor and flue system is to be swept and maintained annually or more frequently if required.

Firebox:

Keep your Fire clean by polishing all over with a soft cloth when unit is cool. In humid climates more interior firebox corrosion will occur in non-use summer months than in winter. The Fires life can be greatly extended by cleaning the firebox interior at the end of winter and spraying with Stovebright high temperature black paint.

NOTES:

Wetback

On special order a wetback model can be supplied. The wetback sits along the back of the firebox. The inlet and outlet are to the side of the fireplace and require standard 25mm pipe connections to the threaded brass pipe of the wetback. Inlet and outlet pipes are at the different height permitting flow of water in one direction and need to be correctly connected by the plumber.

Suggested procedures for soot or creosote fire

In the event of a soot or creosote fire

- Alert all the people in the house. Either have them leave, or be ready to leave.
- Call the fire department.
- Suppress the fire the best you can until the fire department arrives, being careful of your own safety. Be sure you always have a way out of the house should the fire get out of hand.
- **If you can, being careful of your own safety:**
- Discharge a dry chemical household fire extinguisher into the appliance
Use a chimney fire extinguishing product (water on the base of the fire will turn to steam and aid to put out the fire).

Warranty

- Provided the Warmington firebox is installed to manufacturer's specifications we provide a **10-year guarantee** from date of Purchase.
- The black surface, while extremely durable and long lasting, may need buffing lightly with a soft cloth from time to time to retain its colour and appearance or touching up with an approved high temperature paint i.e. Stovebright.

Not included in warranty: (List of Warmington Genuine Replacement Parts)

1. Internal Damper System (Consumable)
2. Ash Pan
3. Bricks
4. Poker
5. Total Flue System
6. Paint (Stovebright)
7. Accessories

Installation

The Warmington unit is to be installed by a Certified Warmington Installer or an Approved NZHHA Installation Technician.